

# NEW CONCEPT MORE EFFICIENCY



**NEW CARMIX  
CONCRETE-MATE:  
THE ULTIMATE  
ELECTRONIC  
SCALE,  
EASY TO USE AND  
EXTRA ACCURATE  
FOR ANY KIND OF  
MIX-DESIGN**



**NEW PROMIX:  
IN-DRUM PROBE,  
TO ANALYZE YOUR  
CONCRETE RIGHT  
IN THE CAB**



**NEW CAB:  
CONFORT, SAFE  
AND VISIBILITY  
MATCHING EDGE  
DESIGN**

## CARMIX 3500TC



gruppocsa.com

## YOUR EVERYWHERE MOBILE BATCHING PLANT

**NEW**



 **METALGALANTE S.p.A.**

Via A. Volta 2 - Noventa di Piave (Venice) ITALY  
T. +39 0421 65191 - F. +39 0421 658838  
Skype: Carmix.main - info@carmix.com

follow us on:



**METALGALANTE S.P.A.**  
certified company

[carmix.com](http://carmix.com)





## WHAT MAKES CARMIX THE BEST OFF-ROAD MOBILE BATCHING PLANT

- **TWO YEARS WARRANTY.**
- **CONCRETE-MATE:** Ultimate "4 sensors" electronic scale, easy to use and extra accurate for any kind of mix design.
- **PROMIX:** New In-drum probe, easy allows to analyze your concrete: slump, volume, temperature, aridity and ready-mix indicator: Your on site Lab! (on request)
- **NEW CAB** confort, safe and visibility matching edge design, front driving cab to assure perfect visibility and excellent comfort to the operator.
- Rich fully equipped cockpit. Ergonomic Joymix; one joystick operates all main functions.
- Self-Articulated hydraulically operating shovel for a more accurate loading of aggregates and cement. 6 buckets only per batch
- Rear engine: easy checks. Fully balanced equipment.
- Oil-bath built-in disc brakes: no maintenance at all and total reliability.
- CARMIX selects the best suppliers in order to assure its customers not only with top quality but also their worldwide after-sale network.
- Among others we are proud to name PERKINS engines, BOSCH-REXROTH transmissions, DANFOSS hydraulic motors, DANA SPICER axles.
- Over 40 years of experience in the toughest jobsites.

# CARMIX 3500TC

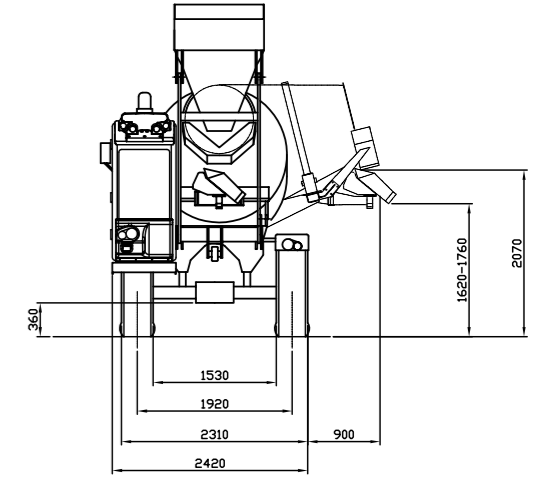
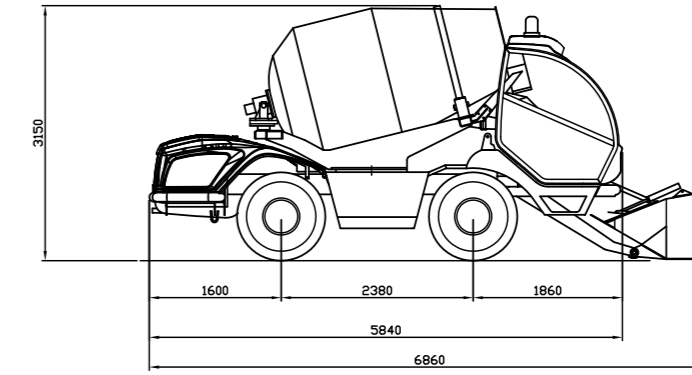

**LOADING SHOVEL:**  
Effective capacity 600 liters, self articulated complete with hydraulic opening gate. 6 buckets only per batch

**NEW CAB:** Confort, safe and visibility matching edge design.

**CONCRETE-MATE:** Ultimate "4 sensors" electronic scale, easy to use and extra accurate for any kind of mix.



# CARMIX 3500TC



**MIXING UNIT:** Drum capacity 4.850 liters. Concrete drum output: 3,5 m3. EN 206-1 IN SLUMP S1 Class, yield not vibrated. Double mixing screws, cover for emergency unloading. Drum rotation by hydraulic motor and planetary reducers. Mixing and discharging speed independent from r.p.m. of diesel engine. Discharging by reversing drum. The mixing unit is slewing hydraulically through 270° for high discharge over 2 m on the four sides of the vehicle.



**CHUTE:** Slewing and hydraulically tilting. Fitted with two pins easily detachable to increase the discharge height.



**WATER SYSTEM:** Self-contained. Hydraulic driven water pump, water meter, washing outlet 400(\*)min High pressure water pump.



**GRADIENT:** Fully loaded 30%.



**ENGINE:** Perkins 1104 D-44 TA Turbo-Diesel, water-cooled, 4 cylinders. Rated power KW 83 (111 HP) set at 2.300 rpm. Engine mounted transversal on the rear.



**BRAKES:** Oil bath disc brakes inside differential axles. Twin independent circuits. Negative hydraulic parking brake.



**TRANSMISSION:** Hydrostatic Bosch Rexroth. Pump and motor are connected to the differentials through a 2 speed reducer (working and transfer). 4 wheel drive and steering.



**TYRES:** Off road industrial type 16/70-20 PR 14.



**AXLES:** Dana Spicer with oil bath disc brakes and planetary reducers.



**STEERING:** Hydrostatic. 3 ways steering. Radius: internal: mm. 1700, external mm 3.700.



**SPEED:** Working speed from 0 to 9 km/h, road transfer from 0 to 25 km/h. Electric servo control.



**NEW ROPS-FOPS CAB:** (UNI 11023) Confort, safe and visibility matching edge design.



**HYDRAULIC SYSTEM:** Three circuits. 2 variable outlet pumps for hydrostatic transmission and drum rotation. 2 gear pumps for services. Inlet and outlet filter. Heat exchanger water/oil-air type.



**JOYMIX:** All hydraulic functions of shovel controlled by a single - fully servo controlled Joystick.



**CONCRETE-MATE:** Ultimate "4 sensors" electronic scale, easy to use and extra accurate for any kind of mix-design.



**PROMIX:** New In-drum probe, easy allows to analyze your concrete: slump, volume, temperature, humidity and ready-mix indicator: Your on site Lab! (on request)



**LOADING SHOVEL:** Effective capacity per load 600 liters, complete with hydraulic opening gate. 6 buckets only per batch.



**ELECTRIC SYSTEM:** 12 Volt. 120 Ah battery for electric starter and road lighting. Safety battery cut-off.



**TANKS:** Water: 2x400 liters. Diesel: 115 liters, (approx. 10 hours work). Hydraulic oil: 80 liters..



**CHASSIS:** Steel profile specially engineered for off-road operations.



**WEIGHT:** About Kg. 7.400. Equally distributed on both axles.



**SAFETY:** Machine equipped with checking and block valves for maximum safety of the operator. Self control avoids drum to slew if shovel's arm is lifted.



**CATALOGUE:** The machine is equipped with Use and Maintenance and Spare Parts Manuals according to CE regulations.

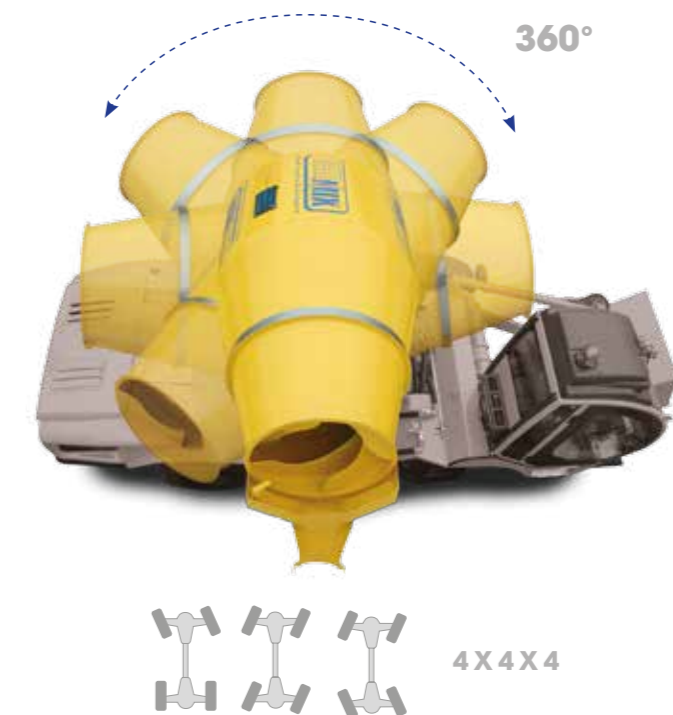

## ACCESSORIES ON DEMAND

PROMIX: In-drum probe, easy allows to analyze your concrete: slump, volume, temperature, humidity and ready-mix indicator: Your on site Lab!

Additive Plant

Clima (air conditioning plus heater)

Air Conditioned

Heater

Spare wheel

Additional discharging chute (cm 100)